

LVDT

Inductive Position Transducer



SL Series

Key-Features:

- Measurement ranges 10...600 mm
- External, or cable electronics with cable break detection
- Linearity up to ± 0.10 % of full scale
- Housing $\varnothing 20$ mm
- Protection class IP67, optional IP68
- Sensor working temperature up to 150°C
- Customized versions available

Content:

INTRODUCTION

LVDTs (Linear Variable Differential Transformers) are inductive sensors excellent for use in harsh industrial environments, e.g. high temperature and pressure ranges, as well as high accelerations and measuring cycles.

The SL series offers ultimate reliability and precision in a small size, and is designed for industrial and lab use. The sensors can also be used under water because of their high protection class and the steel housing.

As of 2013 IMCA and KAB electronics (explanation see page 5) have a built-in cable breakage monitoring and are entirely galvanically isolated. The signal output is optimized for interference compatibility with very low residual noise. The guarantee for ultimate resolution and measuring accuracy.

TECHNICAL DATA

Sensor											
Measurement range FS [mm]	0...10	0...25	0...50	0...80	0...100	0...150	0...200	0...300	0...400	0...500	0...600
Linearity [% of FS]	0.30 % (0.20 % optional); 1.50 % SL500 and SL600, 0.10 % for selected models										
Types	free core, push rod guided/ unguided										
Protection class	IP67, optional IP68										
Vibration stability DIN IEC68T2-6	10 G										
Shock stability DIN IEC68T2-27	200 G/2 ms										
Supply voltage/ frequency	3 V _{eff} /3 kHz										
Supply frequency	2...10 kHz										
Temperature range	-40...+120 °C (150 °C optional, option H, 200 °C on request)										
Mounting	ø 20 mm clamp diameter or rod end bearings										
Housing	stainless steel 1.4571, 1.4305										
Connection	4 core cable or M12-connector with coupling nut										
cable TPE (standard)	ø 4.5 mm, 0.14 mm ² , non-halogen, suitable for drag chains										
PTFE (option H)	ø 4.8 mm, 0.24 mm ² , max. temperature 200 °C, UL-Style 2895										
Max. cable length	100 m between sensor and electronics										
Free core/ push rod/ push rod guided											
Max. acceleration of core/ push rod	100 G										
Life cycle	infinite										
Weight (approx., without cable) [g]	125	150	230	290	320	360	420	550	670	670	670

Electronics	IMCA external electronics (built-in)	KAB cable electronics
Output signal	0...20 mA, 4...20 mA (load < 300 Ohm) 0...5 V, ± 5 V (load > 5 kOhm) 0...10 V, ± 10 V (load > 10 kOhm)	4...20 mA (load < 300 Ohm) 0...5 V, ± 5 V (load > 5 kOhm) 0...10 V, ± 10 V (load > 10 kOhm)
Temperature coefficient	-0,0055, ±0,002 %/K	
Resolution*	0,04 % FS	
Corer frequency	300 Hz/-3 dB (6-pole Bessel)	
Isolation stability	> 1000 VDC	
Power supply	9...36 VDC	
Current consumption	75 mA at 24 VDC 150 mA at 12 VDC	65 mA at 24 VDC 140 mA at 12 VDC
Sensor supply	3 V _{eff} , 3 kHz (adjustable, 1-18 kHz)	
Working temperature	-40...+85 °C	
Storage temperature	-40...+85 °C	
Housing	polyamide PA6.6, meets UL94-V0	ABS
Mounting	on DIN EN-rail	bore diameter ø 5,5

* 98.5% confidence interval (confidence limit)

DIMENSIONS

range (FS) [mm]	body length A [mm]	core length B [mm]	push rod length C [mm]
0...10	107	30	97
0...25	137	50	132
0...50	187	70	177
0...80	247	100	237
0...100	287	120	277
0...150	387	170	377
0...200	487	220	477
0...300	687	320	677
0...400	905	420	887
0...500	905	185	780
0...600	905	185	880

Other measurement ranges are available on request.

type: free core, unguided push rod

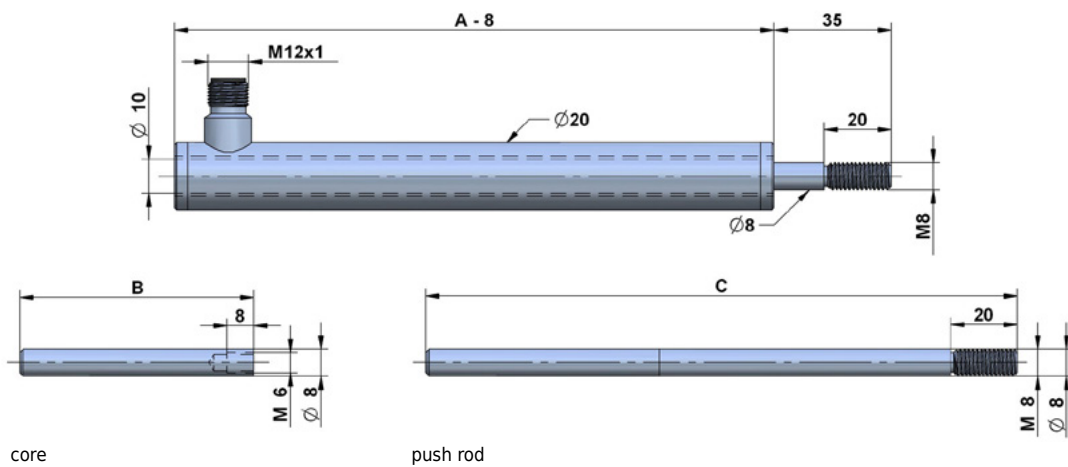

type: guided push rod

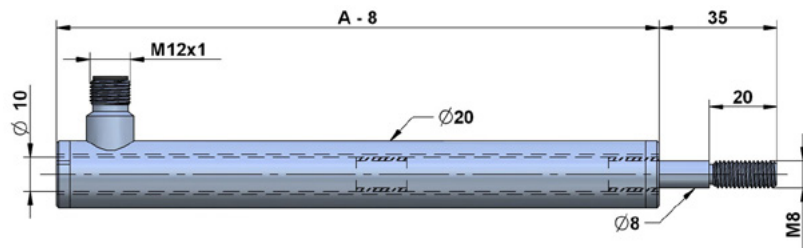

push rod supported by Iglidur bearings, push rod completely extricable

type: rod end bearings

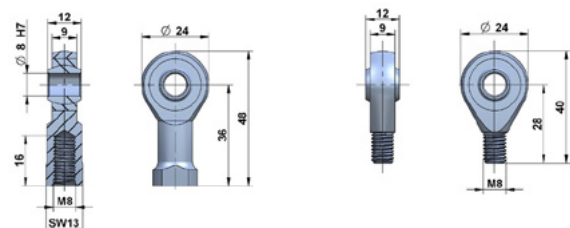
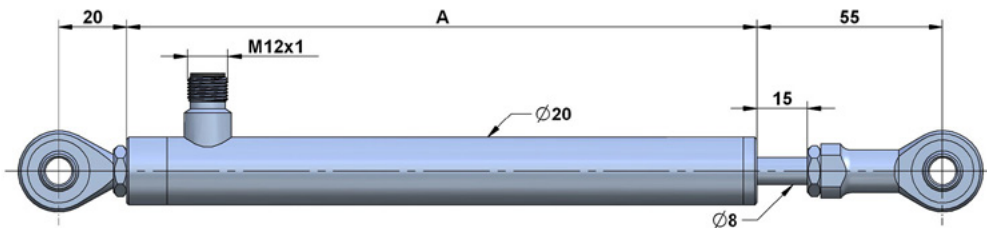

SENSOR TYPES

cable output radial

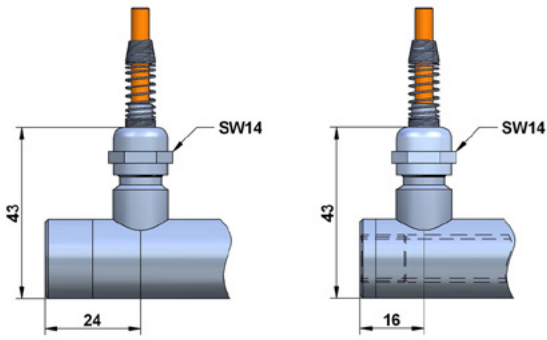

Sensors with cable output have a cable fitting and a spring for bend protection of the cable.

For installation, the bending radius should not be less than 3 times the cable diameter. The standard cable length is 2 m.

Instruments with option H for temperatures up to 150 °C feature a PTFE cable.

Sensors have a through hole. Please use this type for application at heavy dirt exposure. The movement of the push rod removes the dirt from the sensor and conveys it to the rear.

Depending on the application the sensor can - on request - be supplied with a closed rear end body (without additional charge). Please specify that in your order.

connector output radial (cable with straight or angular connector)

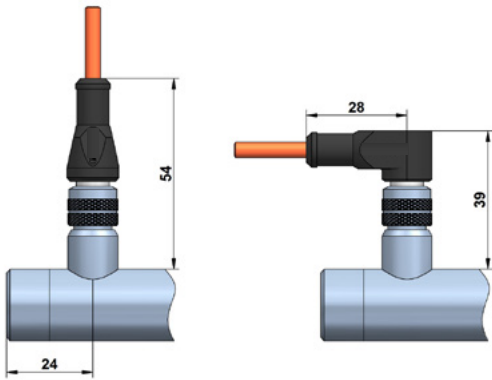

For sensors with connector output the cable has to be ordered separately. You can choose from a cable with a straight connector or with an angular connector.

The connector is protected from accidental removal by a threaded fitting (M12). The cable lengths are 2/5/10 m.

When bolted, the connector pair has the protection class IP67.

wiper ring (option W)

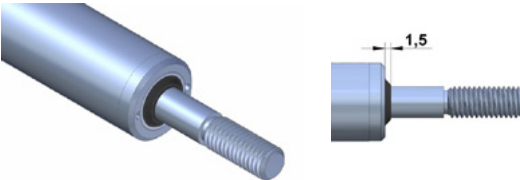

Sensors with guided push rod (type „SG“) or rod end bearings („G“) can be equipped with a wiper ring to prevent the penetration of dust, dirt and metal swarf. The displacement speed of the push rod is limited to 2 m/s and the working temperature to -35...+100 °C.

AC-OUTPUT

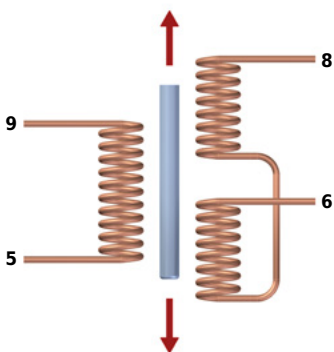

assignment for TPE-cable:

white (5):	primary 2
black (6):	secondary 2
brown (9):	primary 1
blue (8):	secondary 1

assignment for PTFE-cable:

white (5):	primary 2
green (6):	secondary 2
yellow (9):	primary 1
brown (8):	secondary 1

assignment M12-connector:

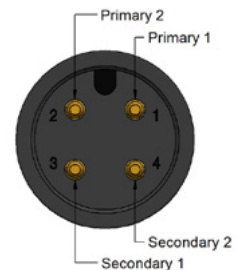

CABLE ELECTRONICS KAB

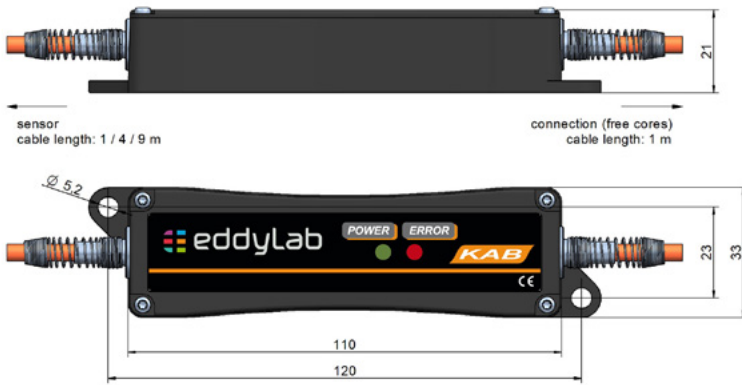

function	cable TPE	cable PTFE-UL
V+	brown	yellow
GND	blue	brown
signal	white	white
signal GND	black	green

If not specified otherwise the cable electronics is placed at 1 m from the end of the cable.

EXTERNAL ELECTRONICS IMCA



external electronics IMCA
(for DIN-rail mounting)

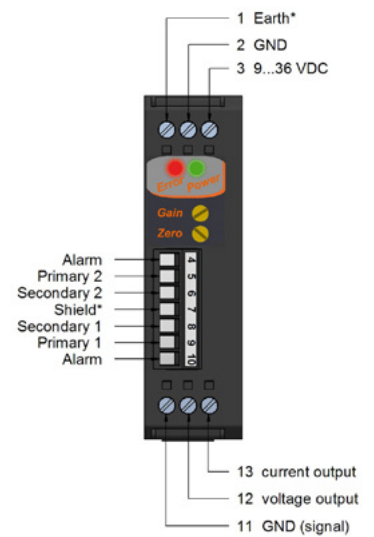
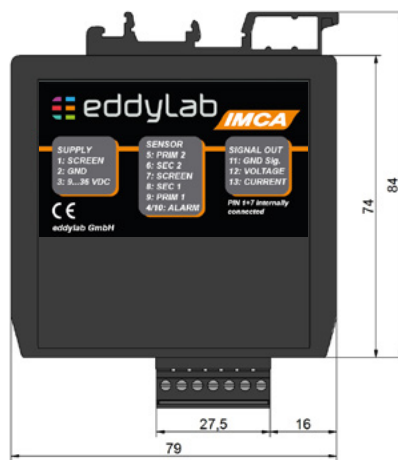

* Terminals 1 and 7 are internally connected.

Connection

The external electronics IMCA is designed to be installed in switch cabinets (Din-rail mounting). The connection to the sensor is conducted as connector with push-in spring connection.

At harsh EMC environments, it is possible to install the electronics at a max. distance of 100 m in a switch cabinet. A twin twisted pair cable (4-cores, minimum cross section 0,5 mm²), single or double shielded, is to be used for the further wiring to connect the external electronics to the system. It is recommended to ground the shield in the switch cabinet near the electronics (do not ground at the machine/ sensor). The sensor housing is grounded at the machine frame. To prevent interference, the cable length should not exceed 100 m.

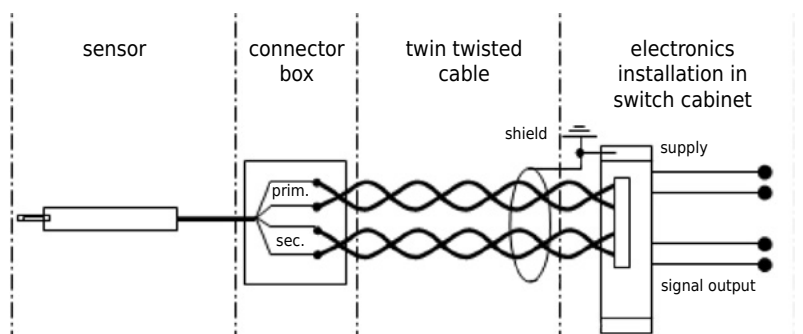

CABLE BREAK DETECTION

The electronics by eddyLab feature a built-in cable break detection. This is achieved by an impedance measurement of the LVDT's secondary coil. If the sensor cable is cut, the impedance on the secondary connections of the electronics change regardless of the push rod position, triggering the cable break detection. This feature is based on a broken secondary connection. A partial cable break of the primary connections (cables between primary coil and electronics) will not activate this function. The electronics vary in their functional range. The external electronics IMCA offers the widest range. The cable electronics KAB only visualises a cable break by a red LED.

IMCA: For the use of the cable break functions an alarm system (signal lamp, acoustic alarm device) or an alarm input of the PLC must be connected to the 7-pole terminal. The circuit board features a analog switch which is a normally open.

Normal operation IMCA:

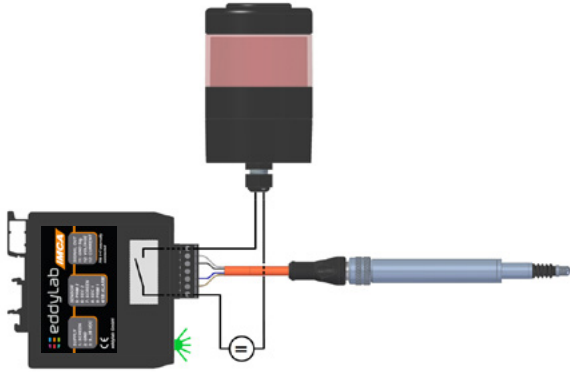

- The green „POWER-LED“ on the front side is on.
- The signal output is active.
- The alarm output is disabled.

Cable break IMCA:

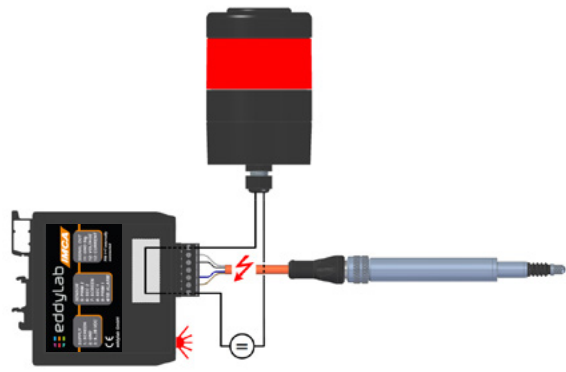

- In case of a cable break the analog switch closes and the alarm system is activated or an electrical signal is conducted. Please note the maximum electrical values: 30 mA or 14 V.
- A front side „ERROR-LED“ flashes in case of an error.
- The signal output is deactivated. There is no current or voltage signal.

Normal operation KAB:



- The green „POWER-LED“ is on.

Cable break KAB:



- The red „ERROR-LED“ is on.

ADJUSTMENT OF ZERO POINT AND GAIN

Please note that the zero point and gain may shift for long cable length between sensor and electronics. Thus install the sensor with the according cable length to the electronics and then adjust zero point and gain.

1. Push rod entirely in - adjust offset
Move the sensor to the zero point of the measuring range and set the offset potentiometer on 4 mA/0 V for the output signal.
2. Push rod entirely out - adjust gain
Move the sensor to the end of the measuring range (push rod moved out) and set the gain potentiometer on 20 mA /10 V/5 V for the output signal.

Signal inversion: If an inverted output signal is required (20...4 mA/10...0 V/5...0 V), swap clamps 6 and 8 (secondary coil) on the external electronics.

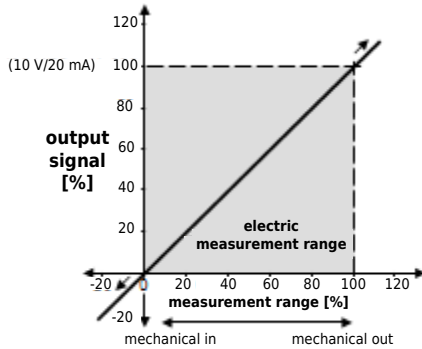

The output signal is referring to the electric measuring range. If the sensor is operated outside the measuring range or the measuring range is exceeded, the signal is also outside the defined range (i.e. > 10 V/20 mA or < 0 V/4 mA, in the graph: > 100 % or < 0 %). Please keep this in mind for control systems with cable break detection lower than 4 mA or for a maximum input voltage > 10 V of measuring instruments. If necessary install the sensor **before** connecting to the plc.

Running direction of signal: If the push rod is moving into the sensor, the signal is reducing. If the push rod is moving out, the output signal is increasing. The running direction of the signal can also be inverted.

ACCESSORIES

Mounting parts

Flanschklemmstück 2030: Flange clamp ø20 mm for SL-series
material: reinforced polyamide
ø30 mm without reducing bush, ø20 mm with reducing bush (included)

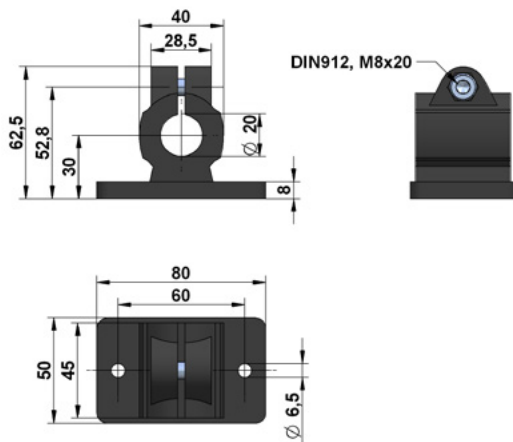

Fußklemmstück 2030: base clamp ø20 mm for SL-series
material: reinforced polyamide
ø30 mm without reducing bush, ø20 mm with reducing bush (included)

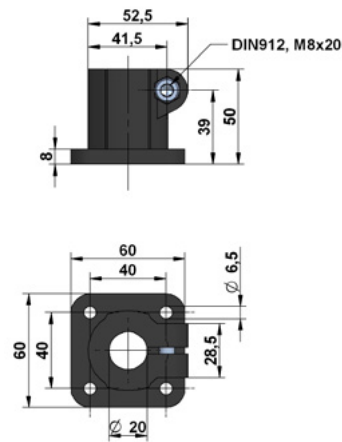

Connection cable (shielded) for connector output

Cable M12 with straight connector

K4P2M-S-M12	2 m
K4P5M-S-M12	5 m
K4P10M-S-M12	10 m

Cable M12 with angular connector

K4P2M-SW-M12	2 m
K4P5M-SW-M12	5 m
K4P10M-SW-M12	10 m



Mating connector M12 for self assembly (shielded)

	Straight connector D4-G-M12-S	Angular connector D4-W-M12-S
Protection class		IP67
Temperature range		-25...+90 °C
Mode of connection		spring closure construction
Cable diameter		ø 4...8 mm
Conductor		0.14...0.34 mm ²
	Good chemical and oil resistance	



ORDER CODE SENSOR

SL **X** - **X** - **X** - **X** **X** **X** **X** **X** **X**
a **b** **c** **d** **e** **f** **g** **h**

a measurement ranges [mm]

10 / 25 / 50 / 80 / 100 / 150 /
 200 / 300 / 400 / 500 / 600

b type

A = free core
 S = unguided push rod
 SG = guided push rod
 G = rod end bearings

c cable / connector

KR = radial cable
 SR = radial connector M12

d cable / connector output

S1: sensor with connector output

1 = radial connector output M12 (no cable)

S2: sensor with cable output, open cable end (for IMCA)

A = TPE cable 2 m
 B = TPE cable 5 m
 C = TPE cable 10 m
 D = PTFE-UL cable 2 m (option H)
 E = PTFE-UL cable 5 m (option H)
 F = PTFE-UL cable 10 m (option H)

S3: sensor with cable output for KAB

G = TPE cable 2 m
 H = TPE cable 5 m
 J = TPE cable 10 m
 K = PTFE-UL cable 2 m (option H)
 L = PTFE-UL cable 5 m (option H)
 M = PTFE-UL cable 10 m (option H)

e linearity

1 = 0,30 % (standard)
 2 = 0,20 % (option L20)
 3 = 0,10 % (option L10)

f temperature range

1 = -40...+120 °C (standard)
 2 = -40...+150 °C (option H)
 3 = -40...+200 °C (option H200)

g push rod sealing

1 = - (standard)
 2 = wiper ring (option W)

h protection class

1 = IP67
 2 = IP68 (option IP68)

ORDER CODE ELECTRONICS

IMCA - 24V - **X**
a

KAB - 24V - **X** - **X**
a **b**

type

IMCA = external electronics
 KAB = cable electronics

a output signal

020A = 0...20 mA
 420A = 4...20 mA
 10V = 0...10 V
 5V = 0...5 V
 ±5V = -5...5 V
 ±10V = -10...10 V

b KAB: type of cable / cable length

E1: for sensor with cable output

- = KAB integrated in sensor cable

E2: for sensor with connector output

A = cable 2 m, M12 straight female connector
 B = cable 2 m, M12 angular female connector
 C = cable 5 m, M12 straight female connector
 D = cable 5 m, M12 angular female connector
 E = cable 10 m, M12 straight female connector
 F = cable 10 m, M12 angular female connector

possible combinations:

- S1: sensor with connector output
- S2: sensor with cable output
- S3+E1: sensor with cable output, KAB integrated in sensor cable

- S1+E2: sensor with connector output, cable electronics with cable K4PxM
- S1+E3: sensor with cable output, cable K4PxM, external electronics IMCA
- S2+E3: sensor with cable output, external electronics IMCA

